

# INTERLOCKED POWER MODULE

## 32AMP 480VAC

(32A 380/440VAC per IEC 309/CEE-17 3h)

Catalog No: R32-480-30-22SE-SP

Item No: 1700-57A

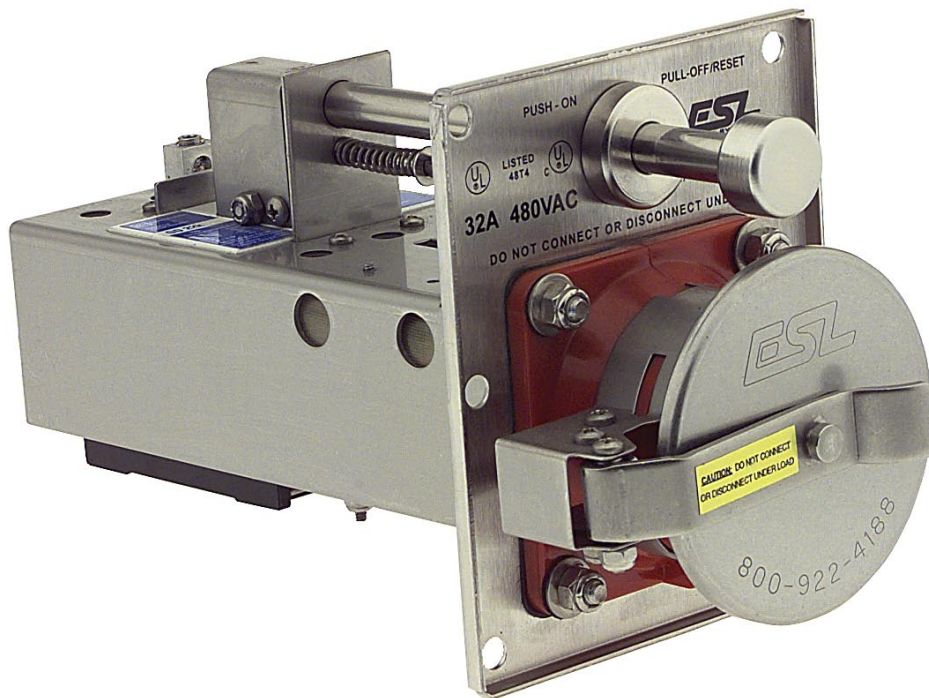

- Heavy Duty Stainless Steel Construction Resists Corrosion & Abuse
- Electrically - Interlocked
- UL Listed Circuit Breaker Protects Operator & Equipment
- Nickel Plated Brass Contacts & Unique Outlet Design Resists Corrosion & Arc Tracking

# SPECIFICATIONS

Catalog No: R32-480-30-22SE-SP

Item No: 1700-57A

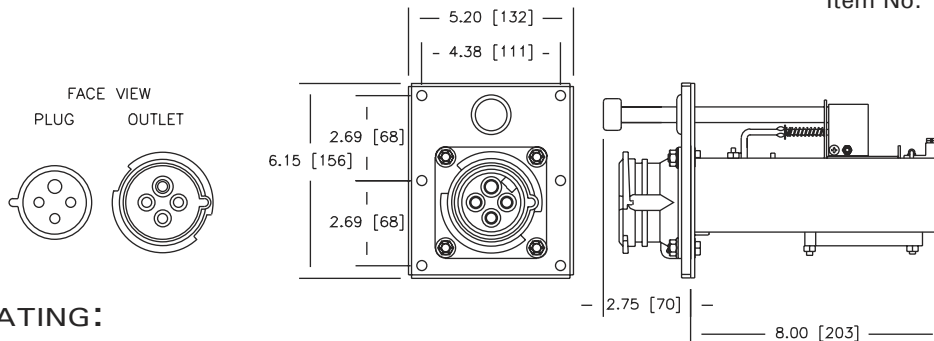

## RATING:

- Receptacle - 32A 380/440V 50/60 Hz (480V 60Hz USA) per IEC 309-2 (CEE-17 3h)
- Circuit Breaker - 30A Trip / 22,000AIC @ 480VAC, Shunt Trip other Trip and AIC ratings available - Contact Factory
- Environmental - IP67 per IEC 529 / IEC 309-1  
(With Mated Plug or Screw Cover) Type 4X capable per NEMA 250, UL 50/508, CSA 22.2
- Terminals - (3) Phase & (1) Ground pressure type screw terminal  
Phase: #10 - #2 AWG (2.5-10mm<sup>2</sup>) Wire Range  
Ground: #10 - #2 AWG (2.5-10mm<sup>2</sup>) Wire Range
- Switch - BZ2RL711, 15A, 480VAC

## MATERIALS:

- Stainless Steel - Frame, On/Off Rod, Interlock Mechanism, Contact Terminal Screws & Spring, Snap Cover, Screw Cover Tether, and all Fasteners
- Nickel Plated Brass - Contact Sleeves
- Polycarbonate (PC) - Receptacle Housing
- Polyamide (Nylon) - Screw Cover (optional)
- Neoprene (CR) - Gaskets, Cover Seals
- Buna-N (Nitrile/NBR) - O-Rings

## APPROVALS:

UL/cUL Listed Module • UL 489 Listed / CSA Certified Molded Case Circuit Breaker

## ACCESSORIES / PARTS

Description	Item No.	Description	Item No.
• Stainless Steel Snap Cover Assy	1500-01	• Micro Switch	4090-11
• Circuit Breaker	4020-20	• Phase Sleeve Kit (set of 3)	4015-01
• Receptacle & Contact Sleeve Assy	4010-05	• Ground Sleeve Kit	4016-03

### ESL Power Systems, Inc.

2800 Palisades Drive • Corona, CA 92880-9427  
 Tel: (951) 739-7020 • (800) 922-4188 • Fax: (951) 739-7048  
 www.eslpwr.com • e-mail: info@eslpwr.com

