

FLANGED CONNECTOR

60AMP 480VAC

Receptacle with Stainless Steel Back Housing

Catalog No: CF60-480-SP

Item No: 1910-03

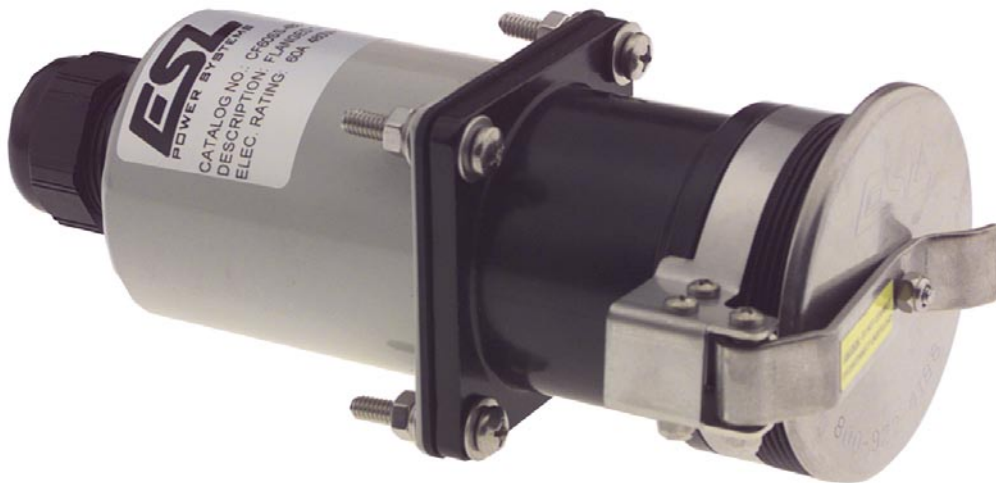

- Heavy-duty Flanged Connector for intermodal applications, shipboard, on rail or over-road. Can be used as an In-Line Connector or can be equipment-mounted using the extra long bolts provided.
- Developed specifically for the severe punishment of underslung gen-set applications, mounted on gen-set or directly to trailer chassis.
- Stainless Steel Self-Aligning Snap Cover standard, Watertight Screw Cover optional.

SPECIFICATIONS

Catalog No: CF60-480-SP

Item No: 1910-03

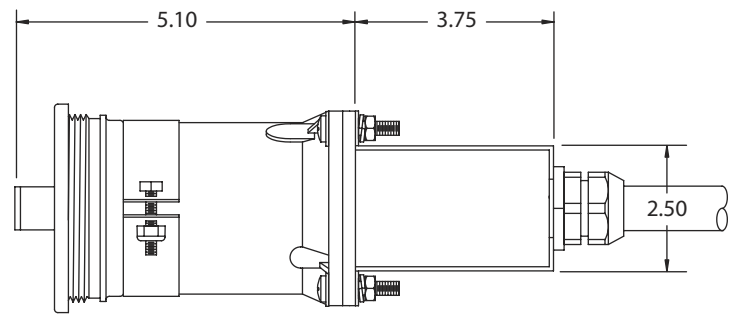
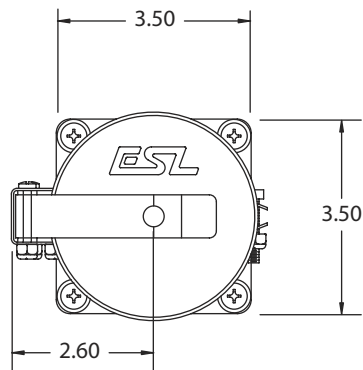

RATING:

Receptacle -	60A 480VAC 3 ϕ + Gr
Environmental -	Meets NEMA 4X
Wire Terminals -	Accepts #6-#10 AWG 4 Conductor SO Cord

MATERIALS:

Stainless Steel -	Terminal Screws, Snap Cover, and all Fasteners
Powder Coated SS -	Rear Housing
Nickel Plated Brass -	Contact Sleeves
Stainless Steel & Rynite Insert -	Receptacle Housing / Insert
Thermoplastic Polyester (PET) -	Screw Cover (optional)
Neoprene (CR) -	Gaskets
Buna-N (Nitrile/NBR) -	O-Rings



ESL Power Systems, Inc.

2800 Palisades Drive • Corona, CA 92880-9427

Tel: (951) 739-7020 • (800) 922-4188 • Fax: (951) 739-7048

www.eslpwr.com • e-mail: info@eslpwr.com

©2005 ESL Power Systems
1910-03